

Pyrotector

INSTRUCTIONS

Explosion-Proof

Air Duct Smoke Detector

Model 30-3003D

APPLICATION

The Pyrotector Model 30-3003D Explosion-Proof Air Duct Smoke Detector is designed to detect the presence of smoke for the primary purpose of controlling blowers and dampers in air conditioning and ventilation systems and is intended for use in classified areas in hazardous industrial and commercial locations. The unit mounts directly to heating, ventilating, and air conditioning ducts and utilizes a cross sectional sampling tube arrangement that allows large volume air sampling. The Model 30-3003D is intended to serve as a supplement rather than a substitute for open area detection.

The air duct smoke detector is intended to be connected to a control unit and function as part of a fire protection system. The Model 30-3003D is designed for use with a 4-wire system fire alarm control panel (2 wires for detector power and 2 wires for detector output).

The detector operates on the forward infrared light scattering principle, a technology that is based on more than 30 years of experience in advanced photoelectric detection systems.

FEATURES

- CSA Certified for Class I, Division 2, Groups A, B, C & D hazardous locations.
- Trouble-free photoelectric operation.
- Standard 4-wire 24 vdc operation.
- Designed to meet ANSI/UL 268A smoke obscuration limits.
- 600 to 4000 ft/min airflow range.
- Rugged design for environmental extremes.

DESCRIPTION

The Model 30-3003D uses air sampling tubes to provide a cross sectional sampling of air moving through the duct. Inlet sampling tubes are available in four lengths: one foot, three feet, six feet, and ten feet. The desired length must be specified when ordering. See the "Ordering Information" section for details.



The length of the inlet sampling tube is determined by the width of the duct to be monitored. The inlet tube should cover the entire width of the duct, therefore, specify the shortest sampling tube that is at least the width of the duct to be protected. It can then be cut to the exact length at the job site.

Outlet tubes are one common length. Both inlet and outlet tubes are furnished with each detector.

DETECTOR OPERATION

When smoke enters the detection chamber, the detector latches into an alarm condition. This results in actuation of an alarm relay, which is connected to the control panel. In addition, an LED located on the detector housing is illuminated to provide a visual indication that a smoke alarm condition has occurred. An auxiliary set of Form C alarm relay contacts is also provided for controlling remote annunciation devices.

To reset the detector, operating power is temporarily interrupted. This action resets the detector and any remote alarm devices or other equipment that is connected to it. It also causes a set of normally closed power supervisory contacts to open, thus annunciating a trouble condition at the control unit.

SPECIFICATIONS

OPERATING VOLTAGE—

20 to 28 vdc filtered supply, with less than 1.4 vpp at 60 to 120 Hz.

OPERATING CURRENT—

Standby: 10 milliamperes.
Alarm: 50 milliamperes.

TEMPERATURE RANGE—

Operating: -13°F to +140°F (-25°C to +60°C).
Storage: -67°F to +185°F (-55°C to +85°C).

HUMIDITY RANGE—

0 to 90% RH non-condensing.

AIR VELOCITY RANGE—

600 to 4000 ft/min.

SENSITIVITY RANGE—

Meets ANSI/UL268A visible smoke obscuration limits:
Grey smoke: 4.0%/ft maximum, 0.5%/ft minimum
Black smoke: 10.0%/ft maximum, 0.5%/ft minimum.

ALARM AND SUPERVISORY RELAY CONTACT RATING—

1.0 ampere at 30 vdc, SPST.

AUXILIARY ALARM RELAY CONTACT RATING—

2.0 amperes at 30 vdc, Form C, SPDT.

JUNCTION BOX—

Body material: Copper-free aluminum.
Cover: Feraloy.
Conduit Fitting: 25 mm (female).

FIBERGLASS ENCLOSURE—

Cover is clear polycarbonate with closed cell neoprene gasket supplied with stainless steel screws.

CERTIFICATIONS—

CSA Certified for Class I, Division 2, Groups A, B, C and D hazardous locations.

WEIGHT—

13 pounds (5.9 kilograms).

DIMENSIONS—

See Figure 1.

SAMPLING TUBES—

Material: Galvanized steel tubing 3/4 inch EMT, length to be specified by customer (1, 3, 6, or 10 feet).
Return Tube: 12 inch standard length tube.

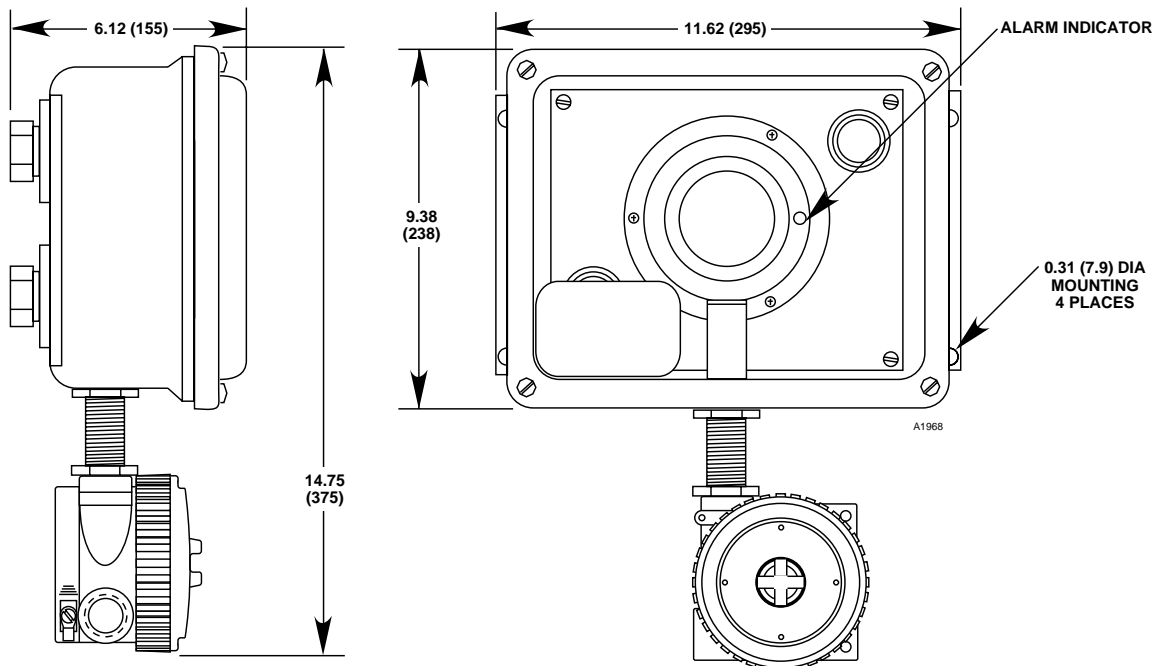

Figure 1—Dimensions of the Model 30-3003D Air Duct Smoke Detector in Inches (MM)

ENGINEERING SPECIFICATIONS

The air duct photoelectric smoke detector shall lock in on alarm and have an alarm indicator LED visible through the air sampling chamber cover. Detectors shall be mounted exterior to the duct, with perforated sampling tubes. Activation of a detector shall cause shutdown of associated equipment through the control circuitry of the fire alarm panel. The detector shall be mounted in a readily accessible location.

The detector shall have SPST alarm contacts for the fire alarm control panel and power supervision. In addition, the detector shall be capable of activating a remote indicating lamp on a remote annunciator.

The detector unit shall be designed for use in Class I, Division 2, Groups A, B, C and D hazardous locations. A junction box shall be furnished for connecting the system wiring.

INSTALLATION

The Model 30-3003D mounts externally on any duct wall with the air sampling and return air tubes extending into the duct to provide a continuous cross sectional sampling of the air moving through the air handling system. Electrical equipment that is used in conjunction with the smoke detector is connected to the detector using a terminal strip located in the junction box that is furnished with the unit.

NOTE

To prevent ignition of a hazardous atmosphere, either de-classify the area or remove power from the unit before opening the enclosure or junction box.

DETECTOR LOCATION

Detectors can be mounted in the supply system downstream of the filters or in the return system at the point of entry into a common return duct. Whenever possible, detectors that are mounted on a return duct should be at a distance equivalent to six duct widths from any duct openings, sharp bends, branch connections, or deflection plates.

For additional information regarding the location and spacing of duct smoke detectors, contact the National Fire Protection Association, Batterymarch Park, Quincy, MA 02269 and request a copy of NFPA Standard 90A, Installation of Air Conditioning and Ventilation Systems and NFPA Standard 72 for Automatic Fire Detectors.

MOUNTING THE DETECTOR

1. Select the location for mounting the detector.
2. Mark and drill the appropriate mounting and sampling tube holes on the duct wall. Refer to Figure 2 to determine the size and location of the holes.

NOTE

To ensure proper operation of the sampling tube within the air duct, be sure to observe proper sampling and return tube position and orientation as illustrated in Figure 3.

3. Attach the return tube to the detector housing by sliding the tube into the connector body and rotating the tube until the key notch slips over the alignment pin in the connector. The opening at the end of the tube is cut at an angle. This opening must always face downstream or away from the direction of air flow in the duct, as shown in Figure 3. Tighten the compression nut until the tube is stable.
4. The sampling tube is available in 1, 3, 6, and 10 foot lengths. As a rule, order the tube that is capable of spanning the entire width of the air duct. For duct widths of three feet or smaller, the sampling tube may be cut to three quarters of the duct width. For duct widths greater than three feet, the recommended practice is to drill a hole on the duct wall directly across from the sampling tube hole of the duct detector. This provides the required support and eliminates excessive stress on the compression nut of the sampling tube connector. Be sure to seal any gap around the hole to prevent air leakage.

NOTE

*When cutting a sampling tube, always cut the end opposite the notches. If the end with the notches is cut, the tube will not seat in the connector fitting properly and proper orientation may not be possible. When the sampling tube is cut to the proper length, install the rubber plug snugly in the end of the tube. **To assure proper detector operation, it is essential that the rubber plug be installed at the end of the sampling tube.***

5. Attach the sampling tube to the detector housing using the compression nut on the connector in the same way that the return tube was installed. Tighten the compression nut until the tube is stable.

NOTE

The holes in the sampling tube must face the air flow in the duct.

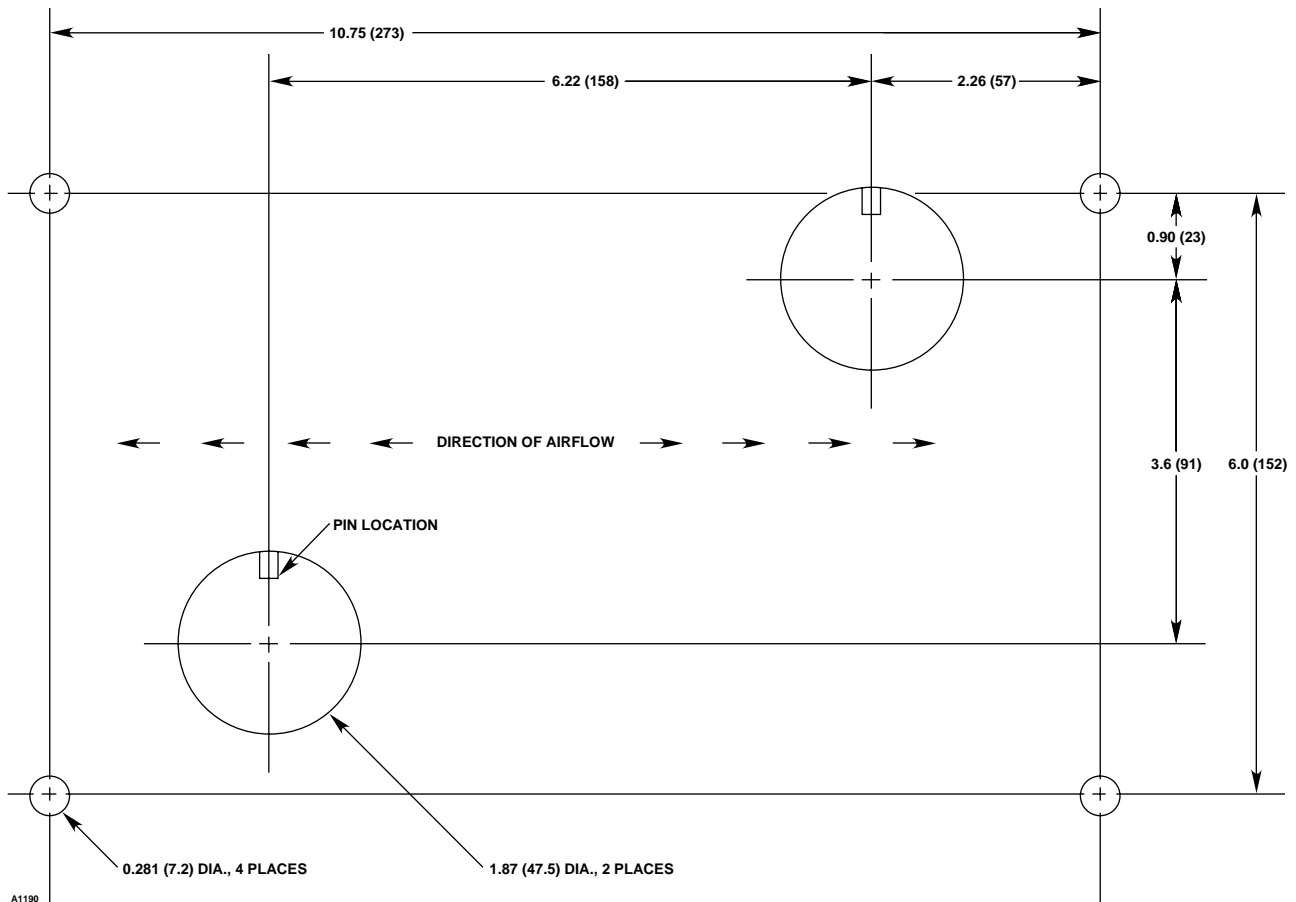

Figure 2—Mounting Hole Dimensions in Inches (MM)

6. Insert the tubes in the appropriate holes in the duct and attach the detector enclosure to the duct using 1/4 inch mounting hardware.
7. External wiring is brought into the detector through the entry on the detector junction box or the M25 to 3/4 inch adapter. Connections are made to the terminal strips TB-2 and TB-3 of the junction box terminal board. Refer to the wiring diagrams in Figures 4, 5, and 6. Use care not to damage the wires by twisting them.

DETECTOR CONNECTIONS

The Model 30-3003D contains four sets of relay contacts.

1. One set of N.O. Alarm contacts close upon detection of smoke.
2. One set of N.C. Trouble contacts close when the detector is powered.
3. One set of N.O. and one set of N.C. Aux alarm contacts.

AIR FLOW MONITORING

The pressure differential between the sampling and exhaust tubes should be tested with the detector mounted and air flowing through the duct. The measured differential should be 0.023 to 1.85 inches of water as measured using a manometer such as the Mark II or No. 460 air meter available from Dwyer Instruments, Inc., P.O. Box 373, Michigan City, IN 46360.

1. Remove the sampling chamber cover.
2. Insert the meter tubes, "low side" to the return tube outlet and "high side" to the sampling tube outlet.
3. If the pressure differential is not within the specified limits, the detector may not function properly. Check the installation to be sure that the return and sampling tubes are positioned and oriented properly. Increasing the air flow within the duct should increase the pressure differential, while decreasing the air flow will decrease the pressure differential. Minor adjustments to the return and air sampling tubes will sometimes bring the pressure differential within specified limits.

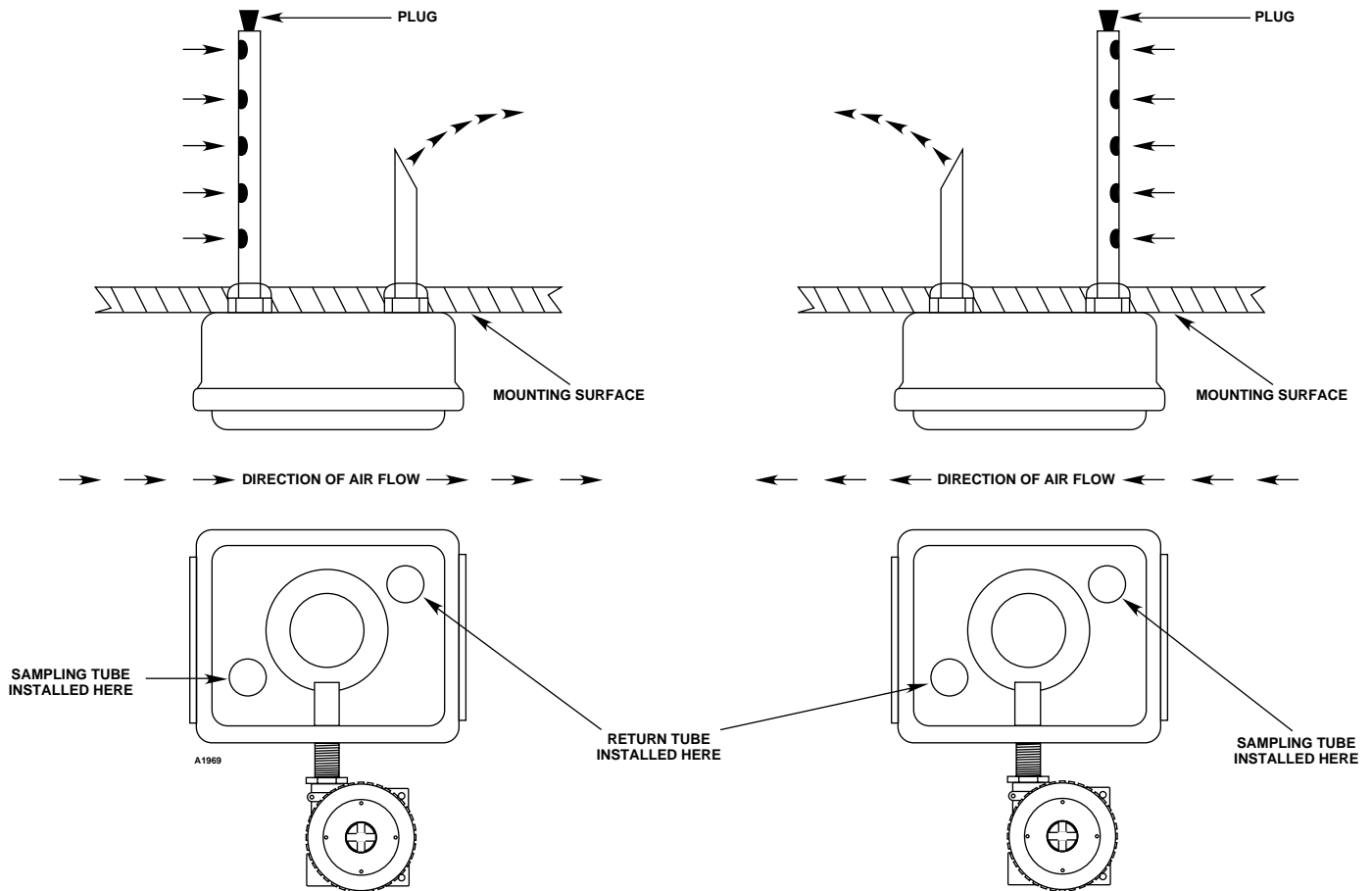

Figure 3—Tube Position and Orientation

TESTING THE DETECTOR

1. Disconnect alarm response devices prior to performing detector tests. Be sure to place this equipment back into service when the testing is completed.
2. Remove the clear front cover from the detector housing.
3. Insert plugs into the sampling and return tube outlets to prevent ducted air from carrying smoke away from the detector sensing head.
4. Apply smoke directly to the detector sensing head using blown cigarette smoke, punk, or cotton wick smoke to cause an alarm. The smoke detector tester manufactured by Home Safeguard Industries can be substituted if the smoke sources listed above are not available. In this case, from a distance of three feet, spray the smoke detector tester into the detector sensing head in short bursts until an alarm condition occurs.

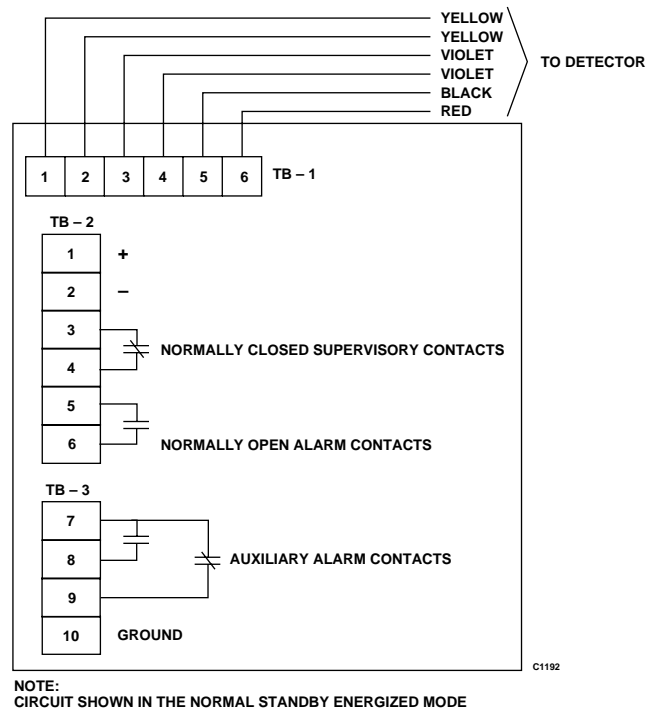

Figure 4—Wiring Terminals

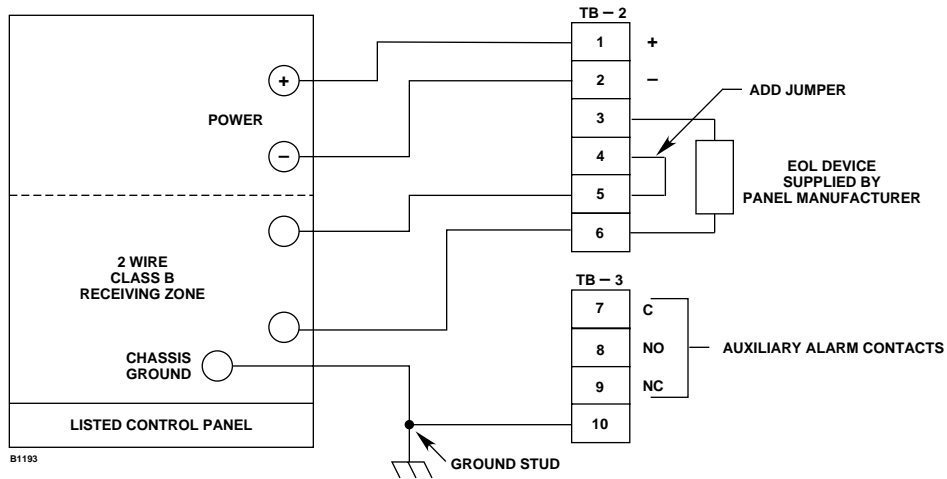

Figure 5—Single Detector Wiring

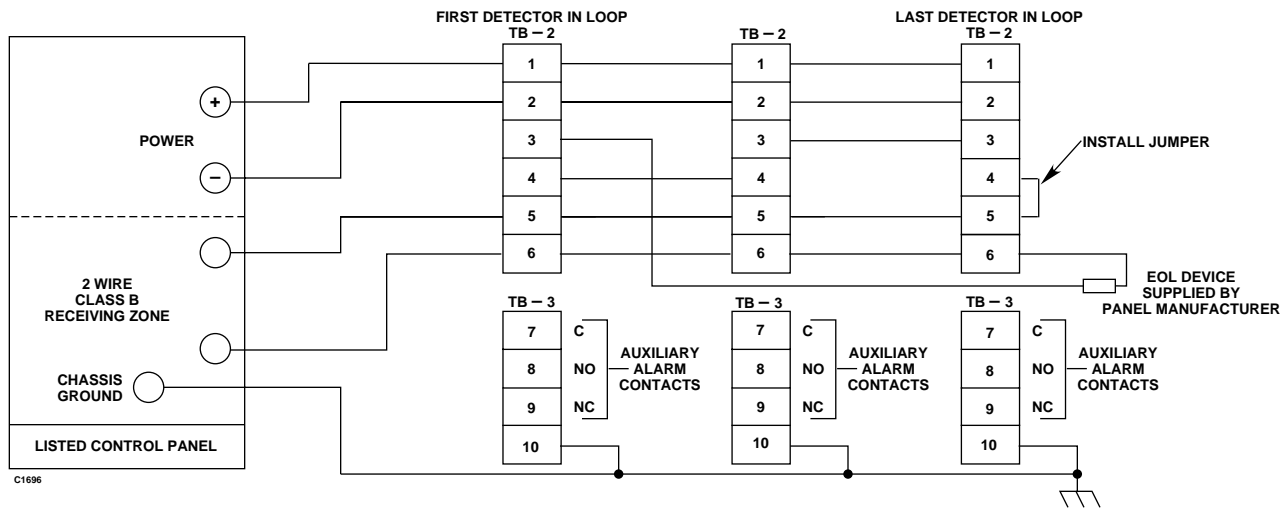

Figure 6—Multiple Detector Wiring

5. Reset the detector by interrupting the input power for approximately three seconds. Resetting the detector can be facilitated by blowing into the smoke detector to clear any residual smoke remaining within the detection chamber.
6. Remove the plugs from the return and sampling tube outlets.
7. Place the clear cover back on the detector housing and tighten screws to provide a positive seal.

The Model 30-3003D Explosion-Proof Air Duct Smoke Detector is not designed to be repaired in the field. If a unit is suspected of being defective, it should be returned to the factory for repair.

MAINTENANCE

The detector should be tested twice a year to ensure proper operation using the procedure described in the "Testing" section of this manual. Proper detector maintenance should also consist of cleaning dust and other contaminants from the sampling and return tubes.

WARRANTY POLICY

Detector Electronics Corporation products are manufactured from high quality components and the completed device is rigorously inspected and tested before shipment; however, any electronic device is subject to failure beyond the control of the manufacturer. To ensure system reliability, it is important to maintain the system as recommended by the instruction manuals and to determine the frequency of functional checking of the system required for each specific installation. The more frequent the checking, the

greater the system reliability. For the highest reliability, a completely redundant system is necessary. The manufacturer warrants its products against defective parts and workmanship, and will replace or repair equipment returned to the manufacturer for these reasons within 18 months after purchase date. See manufacturer's Standard Terms and Conditions on the invoice for complete details. Please note that no other warranties, written or implied, will be honored by the manufacturer.

DEVICE REPAIR AND RETURN

Prior to returning devices or components, contact Detector Electronics so that a Service Order number can be assigned. A written statement describing the malfunction must accompany the returned device or component to expedite finding the cause of the failure. Return all equipment transportation prepaid to the factory in Minneapolis.

ORDERING INFORMATION

When ordering, please specify:

Explosion-Proof Air Duct Smoke Detector
Model 30-3003D

Available duct sampling tube sizes:

Description	Model	Part Number
1 foot length	ST- 1	004783-001
3 foot length	ST- 3	004783-002
6 foot length	ST- 6	004783-003
10 foot length	ST- 10	004783-004
1 foot return tube	RT-1	004736-001

Each detector is shipped ready for installation and is furnished with the following items:

- Air duct enclosure with smoke detector,
- Duct sampling tube of specified length,
- Return sampling tube,
- Rubber stopper,
- Junction box with system wiring terminal connecto,
- Instruction manual.

SPARE PARTS

Description	Part Number
Smoke detector head	102381-001
Circuit board for junction box	004788-002
Rubber plug for sampling tube	102359-001

For assistance in ordering a system to fit your application, please contact:

Detector Electronics Corporation
6901 West 110th Street
Minneapolis, Minnesota 55438 USA
Operator: (952) 941-5665 or (800) 765-FIRE
Customer Service: (952) 946-6491
Fax: (952) 829-8750
Web site: www.detrronics.com
E-mail: detrronics@detrronics.com

Detector Electronics Corporation

6901 West 110th Street • Minneapolis, Minnesota 55438 • Operator (952) 941-5665 or (800) 765-FIRE
Customer Service (952) 946-6491 • Fax (952) 829-8750 • www.detronics.com • E-mail: detronics@detronics.com