

# GENTEX GMH/GMS

## SERIES

### 4" Electro-Mechanical Horn/Strobe Available in Weatherproof

#### Applications

4" low frequency electro-mechanical horn and horn/strobe series that meets and exceeds code requirements for supervised fire alarm systems for the hearing impaired.

The GMH/GMS Series are quality electro-mechanical signaling appliances that offer you both dependable evacuation signals and visual alarms by means of simple screw terminal wiring connections.

The GMH/GMS Series are designed to be used for both new construction and retrofit projects. With the Gentex trim

ring the GMH/GMS can be mounted to a double gang work box in retrofit or new construction.

The GMH/GMS are suited for areas having high ambient noise levels where higher audible output is required. The Z-Series synchronized strobes require the use of the ZMS4 module.

The GMH/GMS appliances are UL 464 and UL 1971 listed for use with fire protective signaling systems and are warranted for 2 years from the date of purchase.



GMH-24

GMS-24

#### Approvals



This symbol on the product's nameplate means it is Listed by UNDERWRITERS LABORATORIES, INC.

- Americans with Disabilities Act (ADA 4.28.3)
- BFP (City of Chicago)
- BS&A/MEA #285-91-E Vol. VII
- CSFM #7135-569:119
- NFPA 72
- UL 464 & UL 1971/1638
- ULC

#### Standard Features

- Low Frequency Penetrating Sound Output
- Low Operating Current
- Screw Terminals, Separate In/Out Field Wiring (12 Gauge)
- Separate Horn and Strobe Functions (Jumper Wires)
- Xenon Strobe Maintains Constant Flash Rate (1Hz) Regardless of Input Voltage

- No Mechanical Contacts
- Textured Plastic High Impact Red Faceplate
- Supplied with Beauty Plugs to Accommodate Mounting Option
- Variety of Standard Mounting Options
- To Synchronize Use the Z Model with the Gentex ZMS4 Control Module
- Outdoor Use Listed (GMH and WGMS)

- 15/75, 30/75 and 110 Candela Strobe Options Meet or Exceed the Requirements of ADA 4.28.3
- UL 464/UL 1971 Listed for Fire Protective Service/Signal for Hearing Impaired

#### Available Models

Model Number	Nominal Voltage	Light Effective Intensity in Candela	Horn Current	STROBE RATED CURRENT @ 24 VDC			In Anechoic Room dBA @ 10 Ft.	In UL Reverberant Room dBA @ 10 Ft. Per UL 464
				Nominal	Start-Up	Peak		
GMH24	24 VDC	—	38mA	—	—	—	95	85
GMS24-15	24 VDC	15	38mA	78mA	114mA	84mA	95	85
GMS24-15/75-W	24 VDC	15 (UL 1971) 75 (UL 1638)	38mA	93mA	130mA	110mA	95	85
GMS24-15/75-C	24 VDC	15 (UL 1971) 75 (UL 1638)	38mA	115mA	140mA	120mA	95	85
GMS24-15/75-Z	24 VDC	15 (UL 1971) 75 (UL 1638)	38mA	130mA	490mA	680mA	95	85
GMS24-30	24 VDC	30	38mA	93mA	130mA	110mA	95	85
GMS24-30/75	24 VDC	30 (UL 1971) 75 (UL 1638)	38mA	142mA	120mA	160mA	95	85
GMS24-60	24 VDC	60	38mA	115mA	140mA	120mA	95	85
GMS24-110	24 VDC	110	38mA	220mA	148mA	240mA	95	85
WGMS-4-75	24 VDC	75 (UL 1638)	38mA	105mA	130mA	110mA	95	85

Note: All 24 VDC models operate from 21-30 VDC -20 +10%

Operating temperature  
Indoor: 32° to 120°F  
Outdoor: -31° to -150°F

0° to 49°C  
-35° to -66°C

#### WHEN PLACING AN ORDER:

add the following to the end of the model number:

- "W" = Wall mount                      "C" = Ceiling mount (15/75, 30/75 and 75 models only)  
"P" = Plain (no lettering)            "Z" = Synchronized strobe (15/75 wall models only)

## Wiring Diagrams

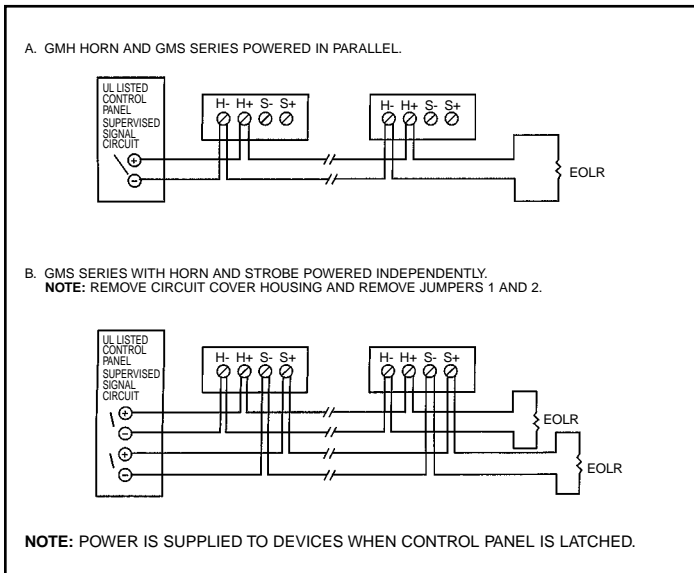

## Dimensions

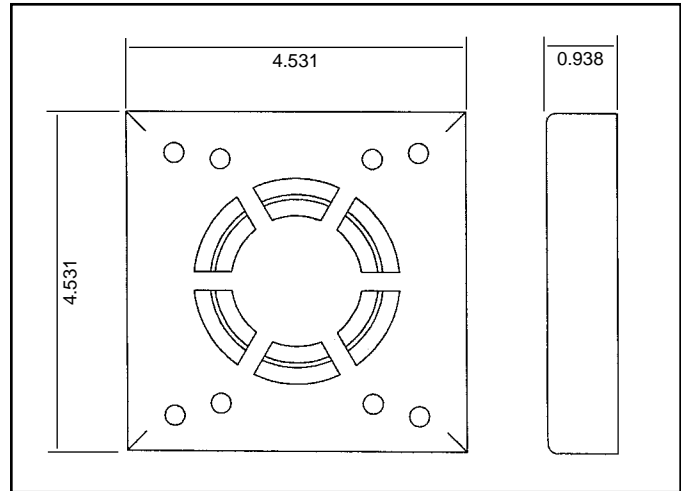

Mounting: 4" square boxes w/brackets 1 1/2" deep minimum  
 4" square metal/non-metallic switch/outlet boxes 1 1/2" deep minimum  
 Gangable 2 gang switch/masonry outlet boxes 1 1/2" deep minimum (with trim plate)  
 WGBB Gentex weatherproof back box

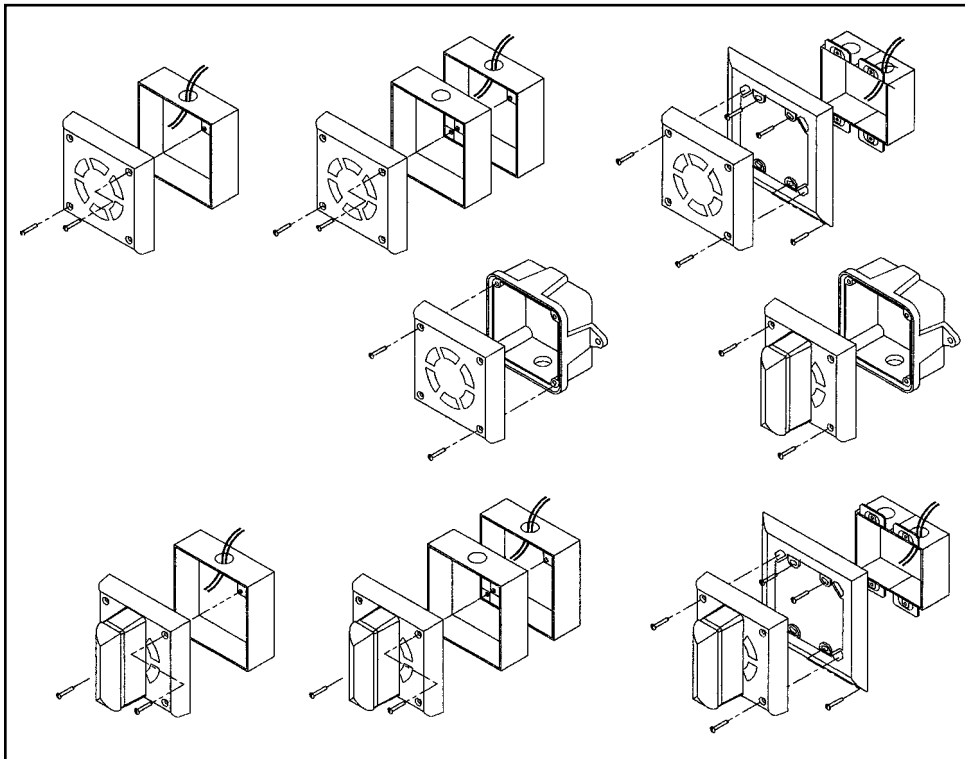

NOTE: Supplied with beauty plugs to accommodate a variety of installations.

## Architect & Engineering Specifications

The audible or audible/visual signal shall be Gentex model GMH or GMS or approved equal, and shall be listed by Underwriters Laboratories per UL 464, and when combined with the strobe option the strobe shall also be listed per UL 1971. The notification appliance shall also be listed with the California State Fire Marshal (CSFM) and the Bureau of Standards and Appeals (NYC).

The notification appliance shall produce a peak sound output of 105dBA or greater as measured in an anechoic chamber.

The visual signal shall have a flash rate of 1Hz regardless of input voltage.

The notification appliance shall be provided with screw terminals for in and out field wiring and the strobe shall be capable of operating independently after the audible has been silenced.

The notification appliance shall be capable of mounting to a 4" square back box and a 2 gang switch box with the Gentex trim ring.

# GENTEX CORPORATION

Fire Protection Products: [www.gentex.com](http://www.gentex.com)  
 10985 Chicago Dr., Box 310, Zeeland, MI 49464  
 616/392-7195 1-800/436-8391 FAX: 616/392-4219

Gentex corporation reserves the right to make changes to the product data sheets at their discretion.



Printed on Recycled Paper

12 units per carton  
 19 pounds per carton GMH  
 20 pounds per carton GMS

GX061394-10